

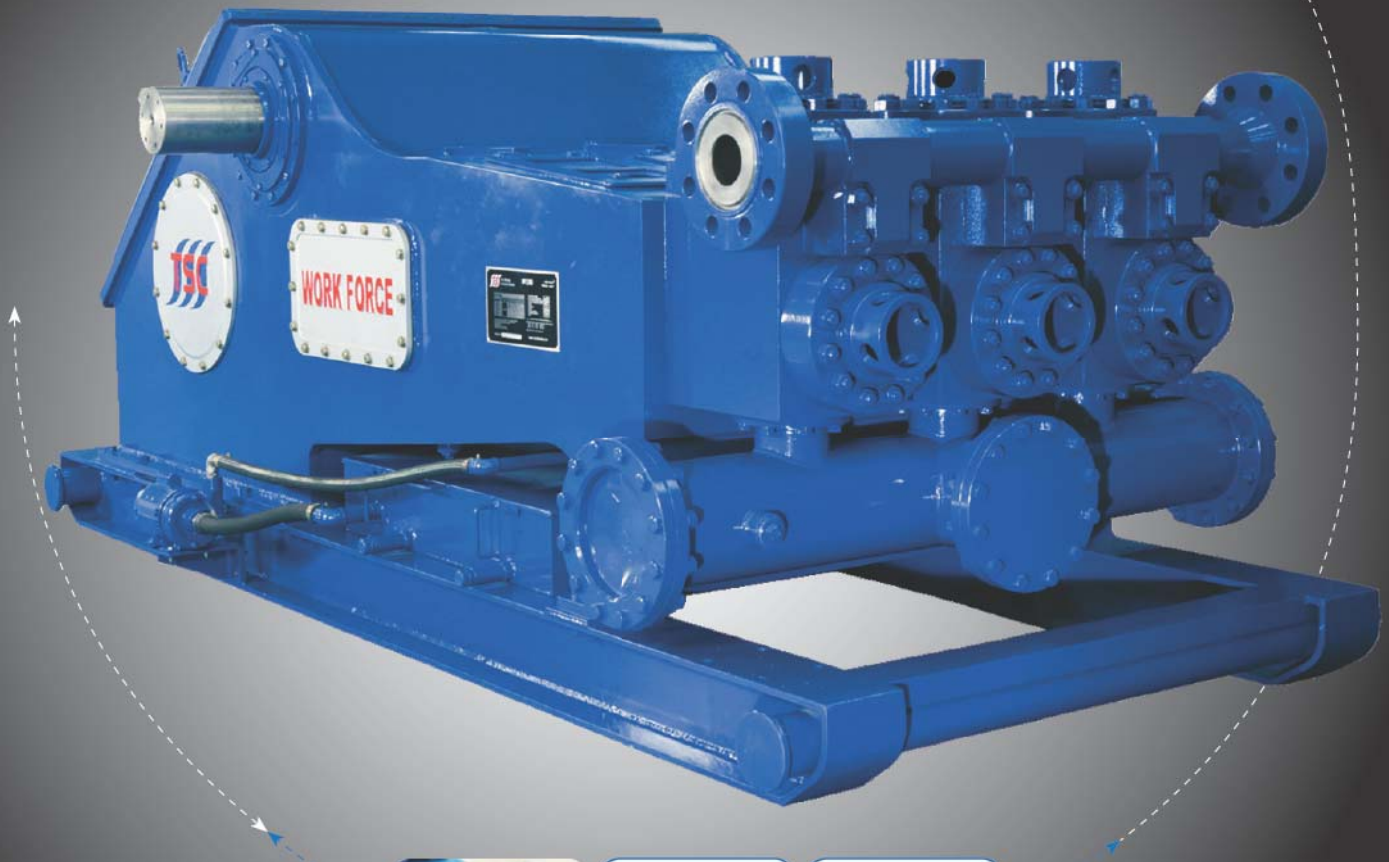

WORKFORCE TRIPLEX PUMP
WORKFORCE™ WF1300 Triplex Pump
WORKFORCE TRIPLEX PUMP



GLOBAL SOLUTIONS

DESIGNING, MANUFACTURING AND PACKAGING FOR THE OIL & GAS INDUSTRY

Beyond Integration
Seamless Solutions™

WORKFORCE™ WF1300

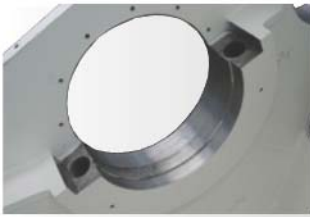

Double-reinforced, 50 Kip high strength, stress relieved, alloy-steel **Pump Frame** provides rigidity where its needed and longevity where its wanted. Heat treatment after fabrication removes residual stress and prevents distortion after final machining.

Forged, welded and heat treated low alloy steel **Connecting Rods** provide optimal operation integrity under continuous load. Fewer welds allow for enhanced durability.

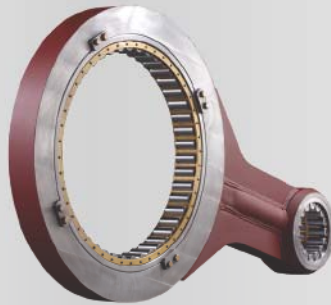

Super Bolt & Nut on Main Bearing cap provide significantly higher yield and tensile strength than the standard hex nut and eliminate the need for special tools not commonly available on drilling rigs.

Premium SKF, Timken or equivalent **Bearings** with minimum L10 life of 30,000 hours at rated load.



Ultra compact, lightweight, harmonically balanced and aligned ground up innovative **Design** results in quiet, low vibration performance, lower operating and transport costs, and industry leading power to weight ratio.

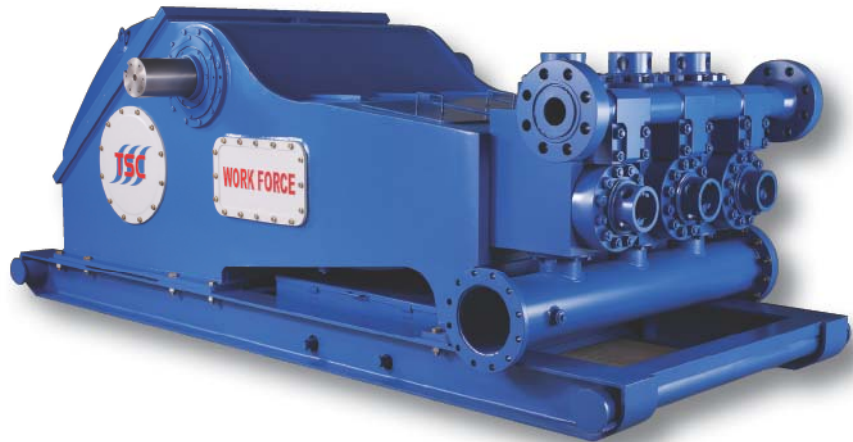

Forged and heat treated, high strength alloy steel ANSI 4340, double helix **Gear** machined to **AGMA 10** & provide longer service life and stronger resistance against chipping under continuous load.



Forged **Pinion** shaft with machined gear made from high strength **ANSI 4340** steel forging for enhanced rigidity and service life.

One piece forged, balanced, and heat treated alloy Steel **Crankshaft** delivers maximum service life. Bolted components allow for easy repairs and optimal sustainability.



Interchangeable with **Multiple OEM** fluid end modules & components for savings in stocking inventory.



TSC Manufacturing and Supply LLC, 13788 West Road, Suite 100, Houston, Texas 77041, USA
Tel: +1 832 456 3900 Fax: +1 832 456 3998 Email: sales@t-s-c.com
Visit our Website at www.t-s-c.com

Why Choose **WORKFORCE™**?

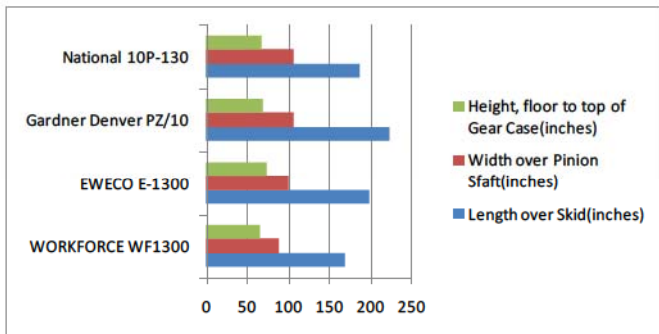

Smaller Footprint, More Horsepower



Lower Cost, Better Value

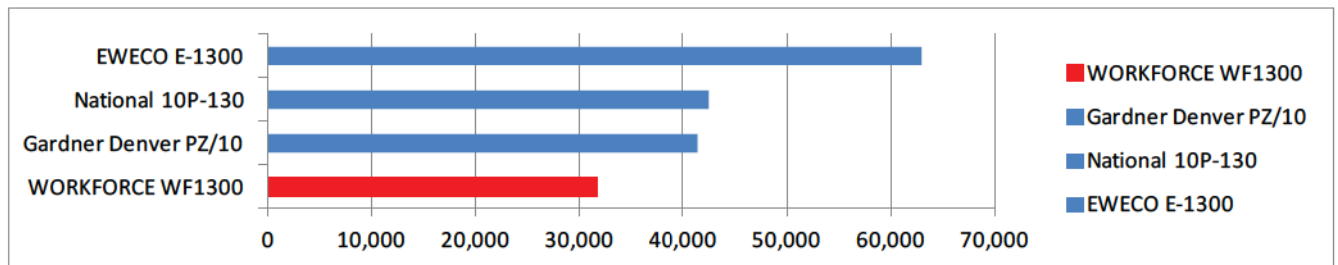

Lighter Weight. More Robust

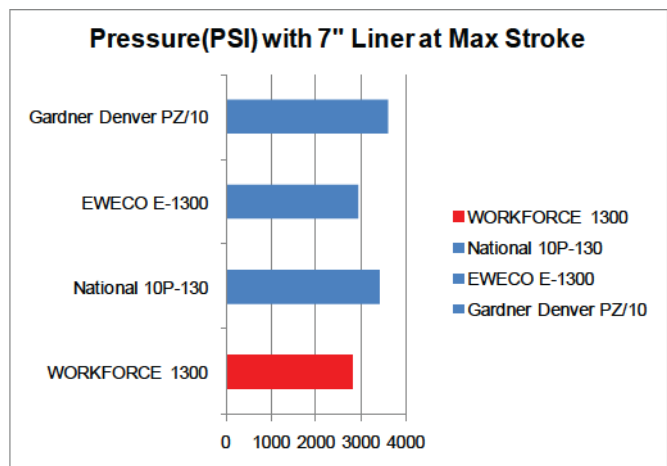
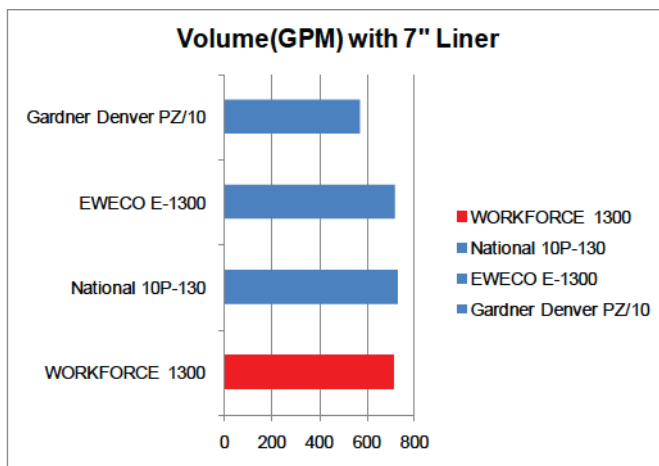

Balanced Performance, Longer Life

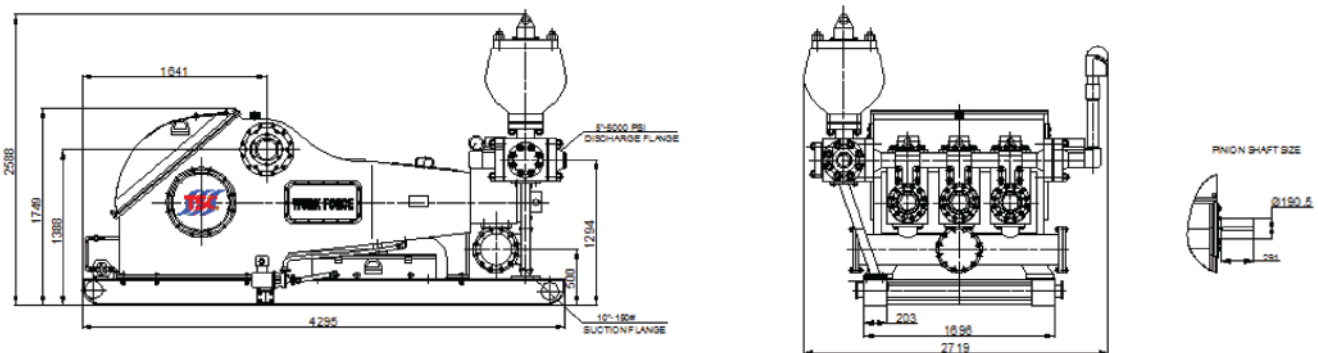

WORKFORCE™ WF1300

Specifications

Nominal Input Power:	1,300 HP (970 kW)
Maximum Continuous Pinion Torque:	11,246 lb-ft
Maximum strokes per minute:	130
Stroke length:	11 inches (279.4 mm)
Gear Ratio:	4.67 : 1
Maximum Piston Diameter & Pressure:	7 inches (177.8 mm) @ 2806 PSI
Minimum Piston Diameter & Pressure:	4 inches (101.6 mm) @ 5000 PSI *
Suction Manifold:	10 inch with 150 pound flanges
Discharge Manifold:	5 inch with 5,000 PSI flanges
Oil Capacity:	150 gallons (606 liters)
Pump Dry weight (including skid):	34,100 lbs (15,500 kg)

* Pressure rating limited to fluid end module and discharge flange ratings

Performance Characteristics

WF1300 Performance Characteristics		Pinion HP	400	600	800	1000	1100	1200	1300
		Pinion lb-ft	11,246						
		Pinion RPM	187	280	374	467	514	560	607
Piston Dia	Pressure	Strokes/min	40	60	80	100	110	120	130
4"	5,000 psi	GPM	71.8	107.7	143.6	179.5	197.5	215.4	233.4
4.5"	5,000 psi		90.9	136.3	181.8	227.2	249.9	272.6	295.4
5"	5,000 psi		112.2	168.3	224.4	280.2	308.6	336.6	364.7
5.5"	4,547 psi		135.8	203.6	271.5	339.4	373.3	407.3	441.2
6"	3,820 psi		161.6	242.4	323.1	403.9	444.3	484.7	525.1
6.5"	3,255 psi		189.6	284.4	379.2	474.0	521.4	568.9	616.3
7"	2,807 psi		219.9	329.9	439.8	549.8	604.8	659.7	714.7

Notes:

- All data subject to change without notice
- All data is based on 100% or continuous duty cycle
- Data is based on 90% mechanical and 100% volumetric efficiency
- Achievable pressure will be limited by input power and fluid end module pressure limitations

Standard Features

- Compact footprint with high horsepower to weight ratio
- Rigid, fabricated oilfield style frame and skid providing a stable platform for pump operation
- Bearings designed for a minimum L10 life of 30,000 hours
- Gears designed to AGMA 8 and 10 specs
- Cast cross heads and guides to maximize longevity
- Fabricated crank shaft with forged core to minimize vibration and insure longevity
- High strength steel used in all drive components
- Allow steel fluid end module with API standard valves and seats and components (PZ-10/11 or F-1000 style as standard)

Options:

- Electrical lube and liner wash pump assemblies
- Discharge strainer cross assembly
- 20 gallon (K-20 style) pulsation dampener
- Pressure relief valve
- Discharge pressure gauge
- Centrifugal charge pump assembly
- Hydraulic seat puller
- Custom unitized package with diesel or electric (AC or DC) drive system

