

WORKFORCE TRIPLEX PUMP
WORKFORCE™ WF1600L Triplex Pump
WORKFORCE TRIPLEX PUMP

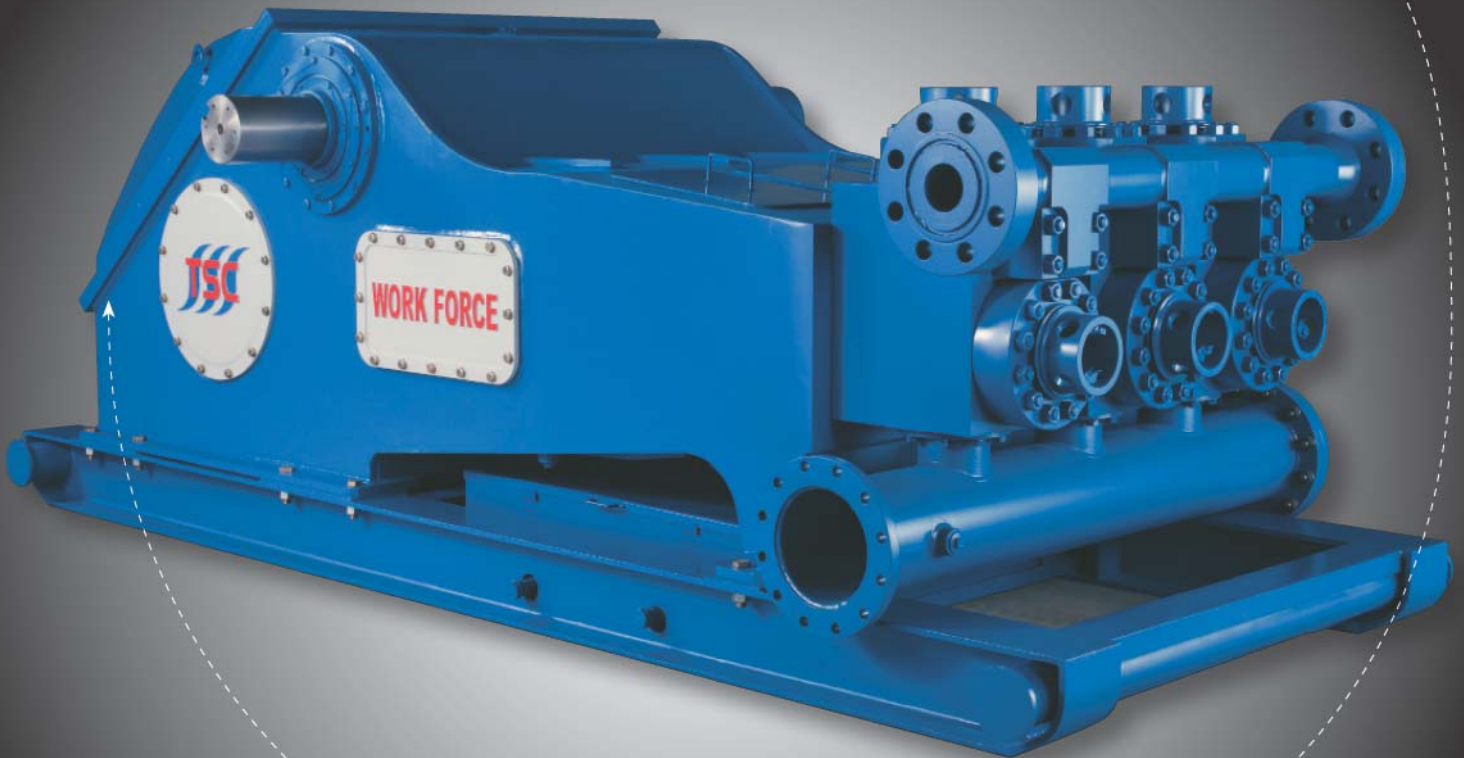

GLOBAL SOLUTIONS

DESIGNING, MANUFACTURING AND PACKAGING FOR THE OFFSHORE INDUSTRY

Beyond Integration
Seamless Solutions™

WORKFORCE™ WF1600L

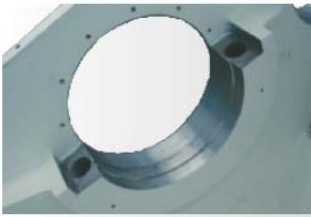

Double-reinforced, 50 Kip high strength, stress relieved, alloy-steel **Pump Frame** provides rigidity where its needed and longevity where its wanted. Heat treatment after fabrication removes residual stress and prevents distortion after final machining.

Forged, welded and heat treated low alloy steel **Connecting Rods** provide optimal operation integrity under continuous load. Fewer welds allow for enhanced durability.

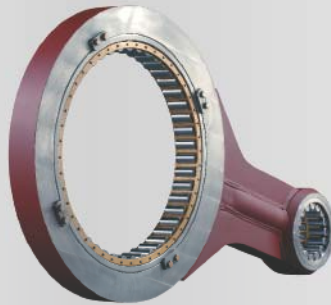

Super Bolt & Nut on Main Bearing cap provide significantly higher yield and tensile strength than the standard hex nut and eliminate the need for special tools not commonly available on drilling rigs.

Premium SKF, Timken or equivalent **Bearings** with minimum L10 life of 30,000 hours at rated load.



Ultra compact, lightweight, harmonically balanced and aligned ground up innovative **Design** results in quiet, low vibration performance, lower operating and transport costs, and industry leading power to weight ratio.

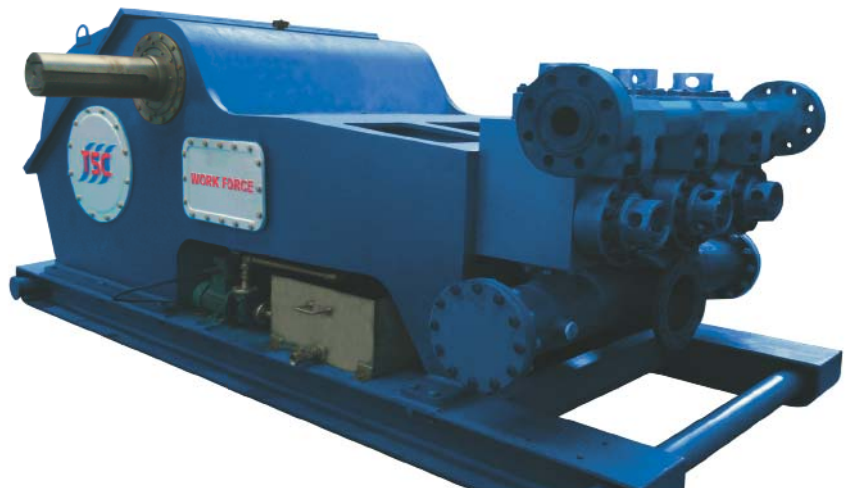

Forged and heat treated, high strength alloy steel ANSI 4340, double helix **Gear** machined to **AGMA 10** & provide longer service life and stronger resistance against chipping under continuous load.



Forged **Pinion** shaft with machined gear made from high strength **ANSI 4340** steel forging for enhanced rigidity and service life.

One piece forged, balanced, and heat treated alloy Steel **Crankshaft** delivers maximum service life. Bolted components allow for easy repairs and optimal sustainability.



Interchangeable with **Multiple OEM** fluid end modules & components for savings in stocking inventory.



TSC Manufacturing and Supply LLC, 13788 West Road, Suite 100, Houston, TX 77041, USA
Tel: +1 832 456 3900 Fax: +1 832 456 3998 Email: sales@t-s-c.com
Visit our Website at www.t-s-c.com

Why Choose WORKFORCE™?

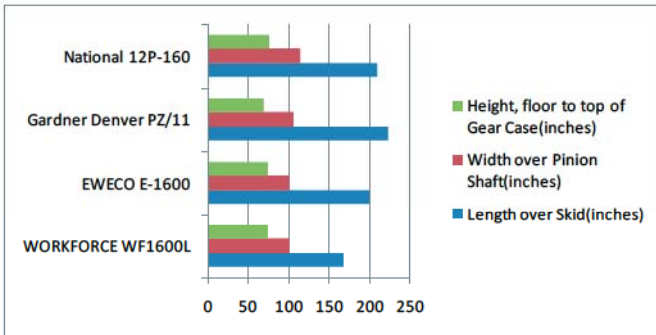

Smaller Footprint, More Horsepower

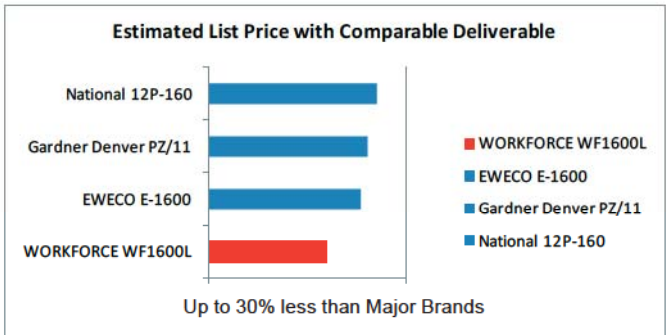

Lower Cost, Better Value

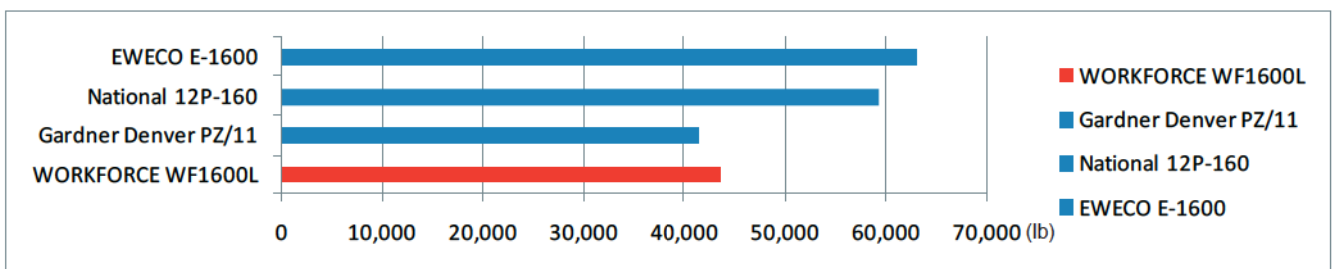

Lighter Weight. More Robust

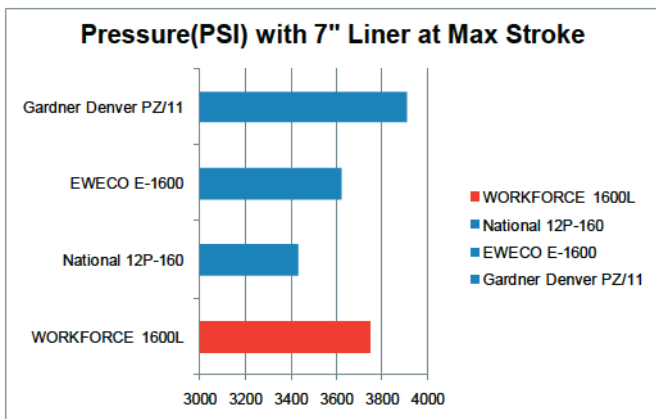

Balanced Performance, Longer Life

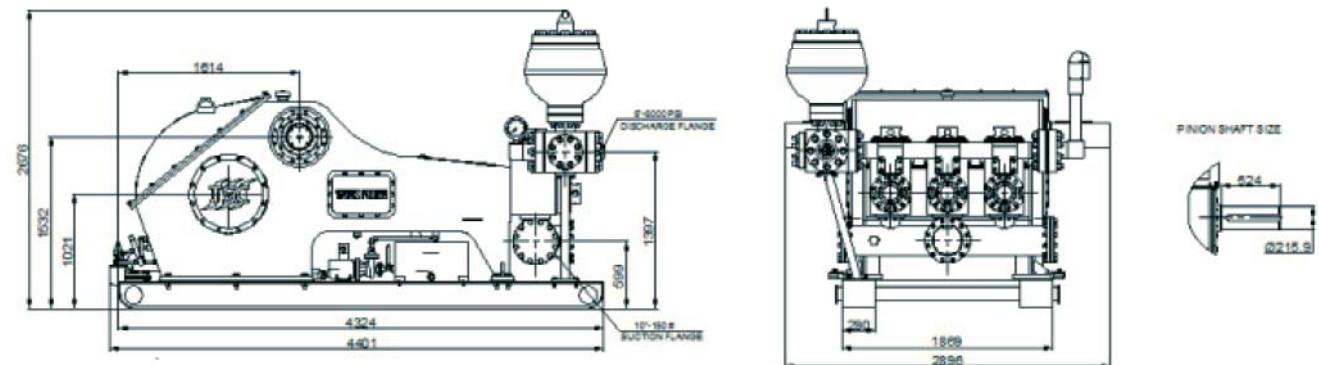
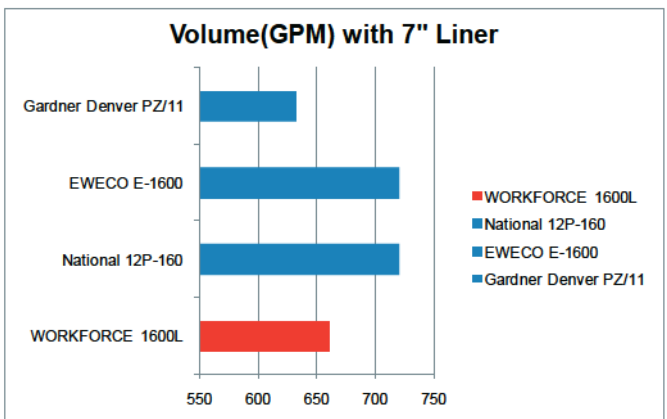

WORKFORCE™ WF1600L

Specifications

Nominal Input Power:	1,600 HP (1194 kW)
Maximum Continuous Pinion Torque:	15,180 lb-ft
Maximum strokes per minute:	120
Stroke Length:	11 inches (279.4 mm)
Gear Ratio:	4.613 : 1
Maximum Piston Diameter & Pressure:	7 inches (177.8 mm) @ 3,741 PSI
Minimum Piston Diameter & Pressure:	5 inches (127 mm) @ 5,000 PSI *
Suction Manifold:	10 inch with 150 pound flanges
Discharge Manifold:	5 inch with 5,000 PSI flanges
Oil Capacity:	120 gallons (450 liters)
Pump dry weight(including skid):	42,400 lbs (19,200 kg)

* Pressure ratings limited to fluid end and discharge flange capacity.

Performance Characteristics

WF1600L Performance Characteristics		Pinion HP	800	934	1,067	1,200	1,333	1,467	1,600	
		Pinion lb-ft	15,180							
		Pinion RPM	277	323	369	415	461	507	554	
Piston Dia	Pressure	Strokes/min	60	70	80	90	100	110	120	
5"	5,000 psi	GPM	168	196	224	252	280	309	337	
5.5"	5,000 psi		204	238	272	305	339	373	407	
6"	5,000 psi		242	283	323	364	404	444	485	
6.5"	4,339 psi		284	332	379	427	474	521	569	
7"	3,741 psi		330	385	440	495	550	605	660	

Notes:

- All data subject to change without notice
- Data is based on 90% mechanical and 100% volumetric efficiency
- Achievable pressure will be limited by input power and fluid end module pressure limitations

Standard Features

- Compact footprint with high horsepower to weight ratio
- Rigid, fabricated oilfield style frame and skid providing a stable platform for pump operation
- Bearings designed for minimum L10 life of 30,000 hours
- Gears designed to AGMA 8 and 10 specs
- Cast cross heads and guides to maximize longevity
- Fabricated crank shaft with forged core to minimize vibration and insure longevity
- High strength steel used in all drive components
- Alloy steel fluid end module with API standard valves and seats and components (PZ-10/11 style as standard)

Options:

- Electrical lube and liner wash pump assemblies
- Discharge strainer cross assembly
- 20 gallon (K-20 style) pulsation dampener
- Pressure relief valve
- Discharge pressure gauge
- Centrifugal charge pump assembly
- Hydraulic seat puller
- Custom unitized package with diesel or electric (AC or DC) drive system



WORKFORCE™ MAKE THE DIFFERENCE

WORK FORCE™

- ✓ **Innovative Design** - Compact, lightweight, harmonically balanced and aligned
- ✓ **Frame** - Robust, double reinforced 50 Kip high strength, heat treated, stress relieved low alloy steel, designed for discharge pressure up to 7500psi
- ✓ **Crankshaft** - Forged and heat-treated alloy steel, balanced, mounted to the power frame with double-row, self-aligning radial spherical roller bearings
- ✓ **Connecting Rod** - Low alloy steel, forge-welded and heat-treated
- ✓ **Bull Gear** - Forged and heat-treated, alloy steel ANSI 4340, double helix gear machined to AGMA grade 10
- ✓ **Pinion Shaft** - Forged and heat-treated, alloy steel ANSI 4340, double helix gear machined to AGMA grade 10, teeth surface hardened to BHN 360-400
- ✓ **Bearing** - Premium SKF, Timken or equivalent bearings typically with minimum L10 life of 30,000 hours at rated load
- ✓ **Crosshead** - Nodular ductile, cast iron with interchangeable slides
- ✓ **Super Nut** - on Main Bearing cap in lieu of Hex nuts
- ✓ **Lube System** - AC Electrical system standard
- ✓ **Fluid End Modules** - Interchangeable with Multiple OEM fluid end modules & components
- ✓ **Rubber Sealing Components** - American rubber components standard

Common Generic Brands

- **Design** - Generally copied from antiquated designs. Functional, but are generally characterized to be unbalanced, heavy, large and comparatively lower power to weight ratio
- **Frame** - Uses a 32 Kip welded steel plating capable of handling discharge pressure to 5000psi on the power frame
- **Crankshaft** - Cast Alloy steel single or multi piece core with welded components
- **Connecting Rod** - Cast, 3 piece welded steel Connecting Rods
- **Bull Gear** - Gear from ANSI 4140 steel, forged, machined to AGMA grade 8, teeth surface hardened to BHN 270-300
- **Pinion Shaft** - Forged Pinion shaft, gear machined to AGMA 8, teeth surface hardened to BHN 320-350
- **Bearing** - Chinese made bearings with L10 life of or less 15,000 hours under rated load
- **Crosshead** - slides are not interchangeable
- **Chinese made hex nut** with generally inconsistent yield strength
- **Generly used Lube system** - not offered as standard
- **Fluid End Modules** - Interchangeable with only single OEM counterpart
- **Rubber Sealing Components** - Chinese made rubber components standard



WORKFORCE™ Triplex Pump

- Localized Service through a Global Network
- Maintenance/Repair Service
- Alignment, Clearance & Tolerance Adjustments
- Internal Repair/Replacement Service
- Closed Circuit Pressure Testing
- Unitized Pump Packages with Diesel or Electric Drive
- Complete Pump Refurbishment
- 24x7x365 Technical Support

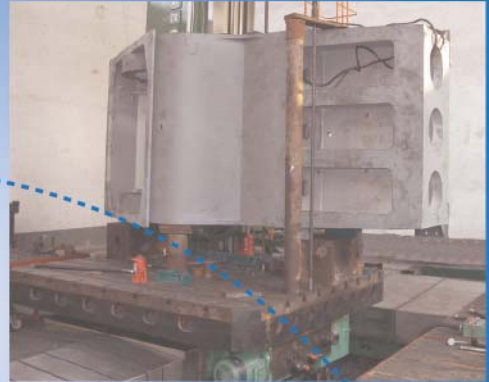

- API 7K, Q1 & ISO 9001 Certified
- World Class R&D Team
- Fully Stocked Local Inventories
- Wholly-owned Manufacturing Facilities
- Global Quality System

- Worldwide Immediate Parts Support
- Mature Global Supply Network
- Available Maintenance Agreements
- Rental Services
- In House Financing Available on Volume Orders

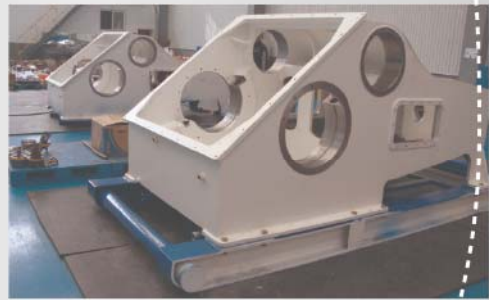

TSC, Casper, WY

TSC, Midland, TX
TSC, Kilgore, TX
TSC, Houston, TX
TSC, Alice, TX

TSC, Cd Del Carmen

TSC, Maracaibo
TSC, Anaco
TSC, Bogota
TSC, Quito

TSC, Macae
TSC, Rio de Janeiro

TSC, Aberdeen
TSC, Shipley
TSC, Birmingham

TSC, Moscow

TSC, Dubai

TSC, Beijing
TSC, Qianan
TSC, Qingdao
TSC, Xi'an
TSC, Zhengzhou

TSC, Hongkong

TSC, Singapore



TSC Manufacturing and Supply LLC, 13788 West Road, Suite 100, Houston, Texas 77041, USA
Tel: +1 832 456 3900 Fax: +1 832 456 3998 Email: sales@t-s-c.com
Visit our Website at www.t-s-c.com

04/2014